



GRAVIC GROUP

THERMAL MANAGEMENT AND
EMI SHIELDING SOLUTIONS



www.gravicgroup.com

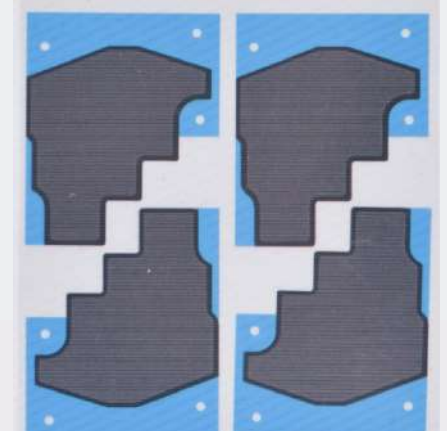

TABLE OF CONTENT

1	THERMAL INTERFACE MATERIALS	03	5	PRODUCT CATALOGUE	20
2	SOFT SHELL BATTERY MODULES	10	6	EMI SHIELDING MATERIALS	25
3	HARD SHELL BATTERY MODULES	14	7	OTHER THERMAL PRODUCTS	29
4	CHARGING PILE MODULES	18			

THERMAL INTERFACE MATERIALS

TYPICAL APPLICATIONS



ENERGY STORAGE BATTERY

POWER BATTERY

CHARGING PILE

TYPICAL APPLICATIONS

BATTERY MODULE

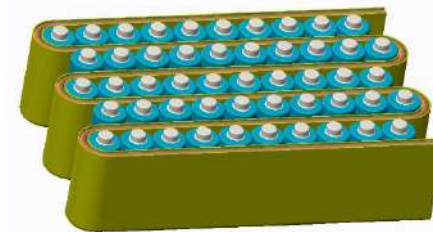

CHARGING PILE CASE

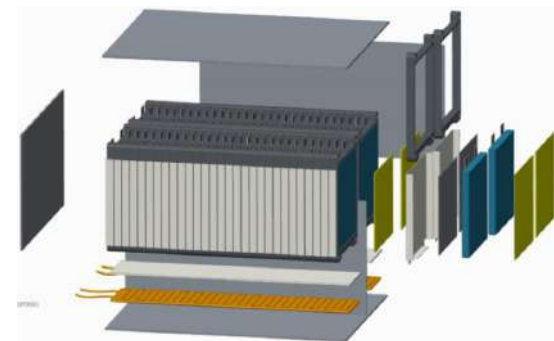

AIR COOLING STRUCTURE OF LITHIUM ION PHOSPHATE BATTERY MODULE

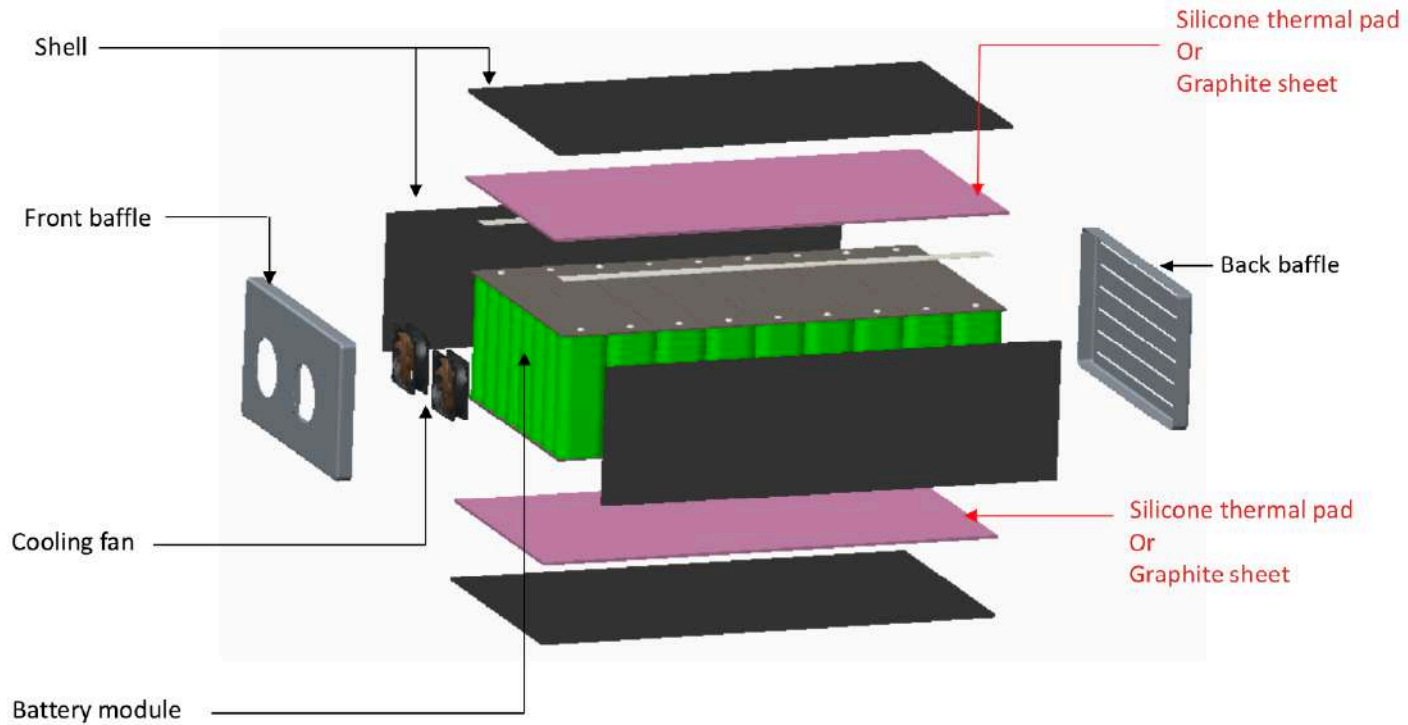

LIQUID COOLED STRUCTURE OF 18650 ELECTRIC POWER BATTERY MODULE

liquid cooling tube

Silicone thermal pad / graphite sheet

18650 lithium cell

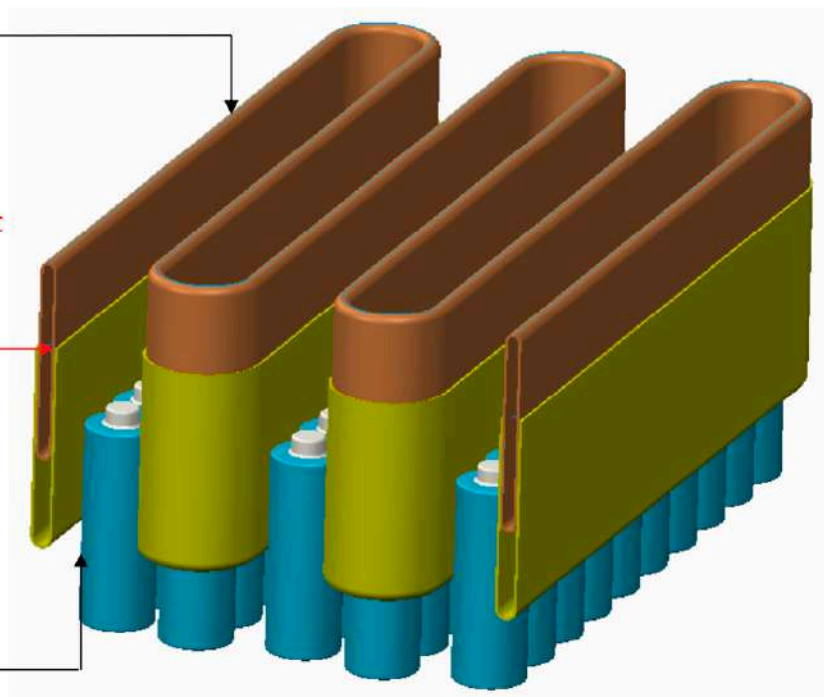

LIQUID COOLED STRUCTURE OF 18650 ELECTRIC POWER BATTERY MODULE

1. The heat generated by the working battery cells is transferred to the liquid-cooled tube through the thermal interface materials.

The heat is carried away by the free circulation flow of the coolant, which makes the temperature of the whole battery pack unified and balanced.

The strong specific heat capacity of the coolant absorbs the heat generated by the working battery cells and makes the whole battery pack operate at a safe temperature.

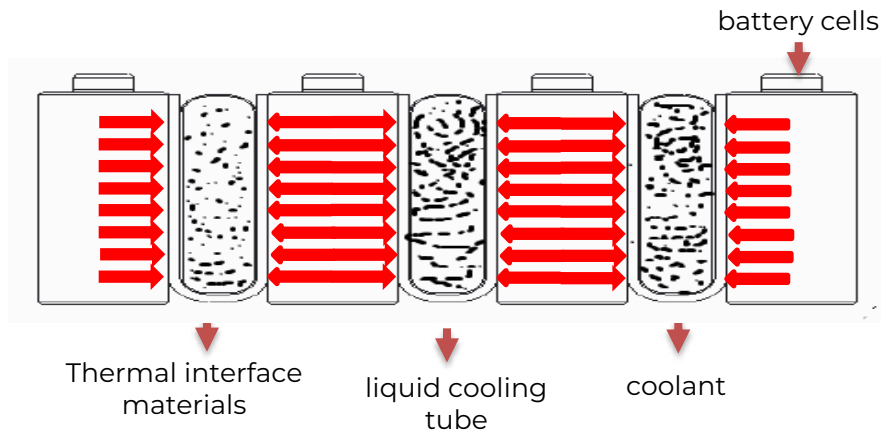
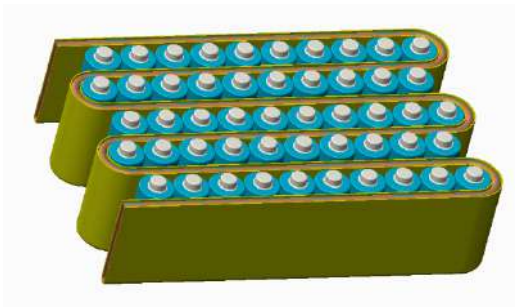

2. The silicone thermal pad with good insulation and high resilience toughness, can effectively avoid the vibration between the cell friction damage, and the hidden danger of short circuit between the cells.

It is the best auxiliary material for water cooling program.

HEAT DISSIPATION MODE OF LIQUID COOLING STRUCTURE FOR POWER BATTERY PACK

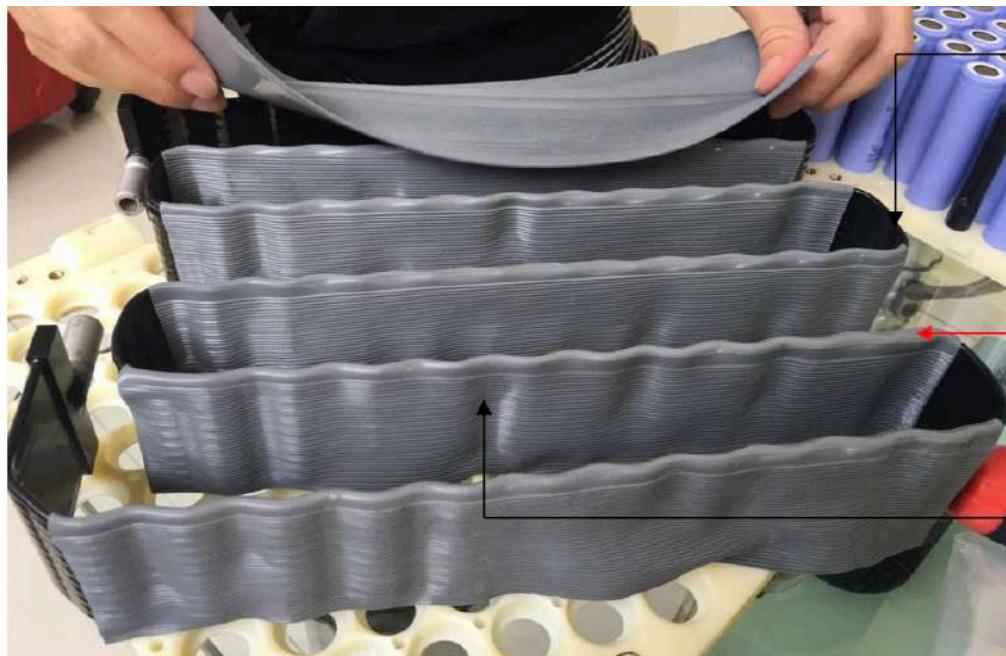

S type liquid cooling tube

Heterotypic silicone thermal pad

The lithium cell is placed in the middle, so that the whole liquid cooling tube is wrapped around the cell.

TEMPERATURE RISE SIMULATION OF POWER BATTERY PACK LIQUID COOLING STRUCTURE

- Temperature difference on the cross section
- The temperature of the cell is balanced and the temperature difference is small.
- The working temperature of the cell can be well controlled.

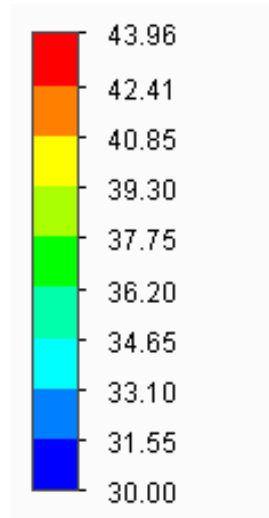

Temperature (solid) °C

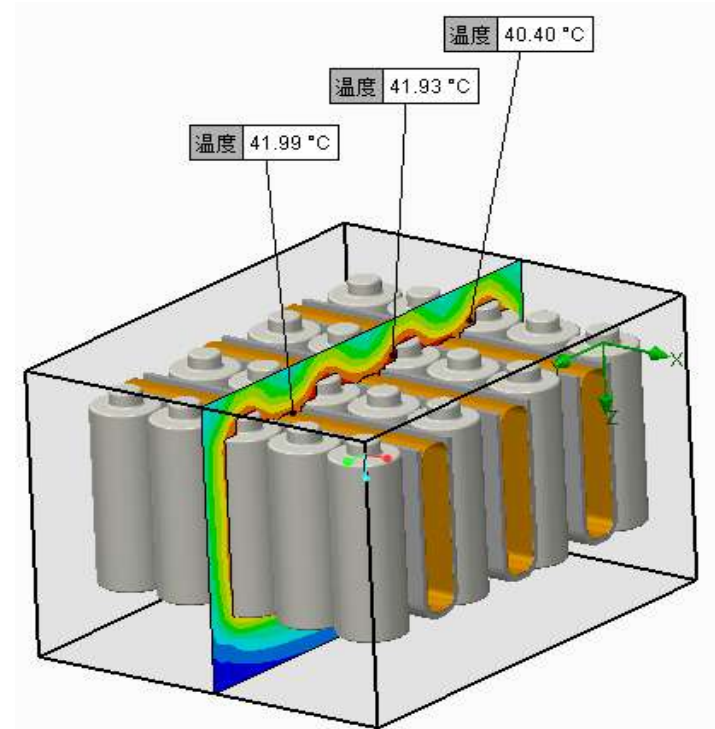

SOFT SHELL BATTERY MODULES

SOFT SHELL BATTERY MODULES

STACKED STRUCTURE OF SOFT BATTERY MODULE

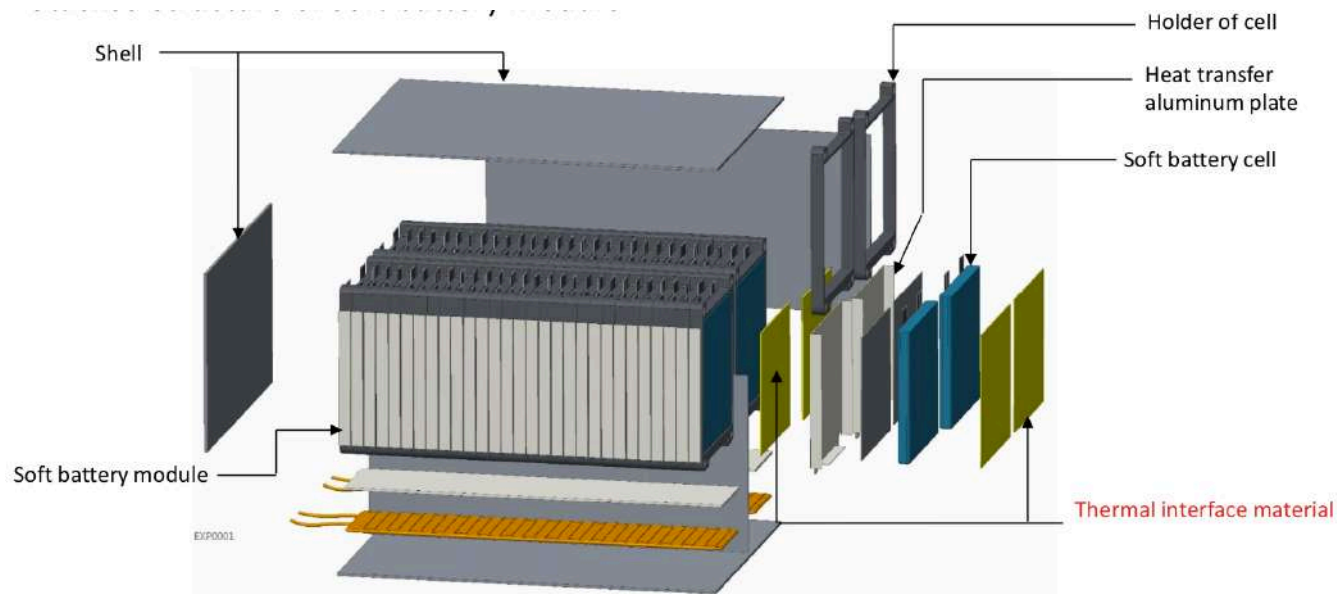

STACKED STRUCTURE OF SOFT BATTERY MODULE

1. This scheme is applied to the new energy vehicle battery module. When the temperature of the battery is too low, the preheater is started first, and the heat is transferred to the heat transfer aluminum plate in the battery pack through the thermal interface material, then the battery module can be preheated uniformly and efficiently. When the battery cell runs overheated, the heat of the cell is transferred to the heat transfer aluminum plate through the thermal interface material, and then to the metal shell, which can quickly dissipate heat and ensure the stable operation of the battery module.
2. The thermal interface materials have good insulation and wear resistance, which can effectively protect the friction between the battery pack, heating sheet and shell and it can avoid wear, short circuit and other related safety problems.

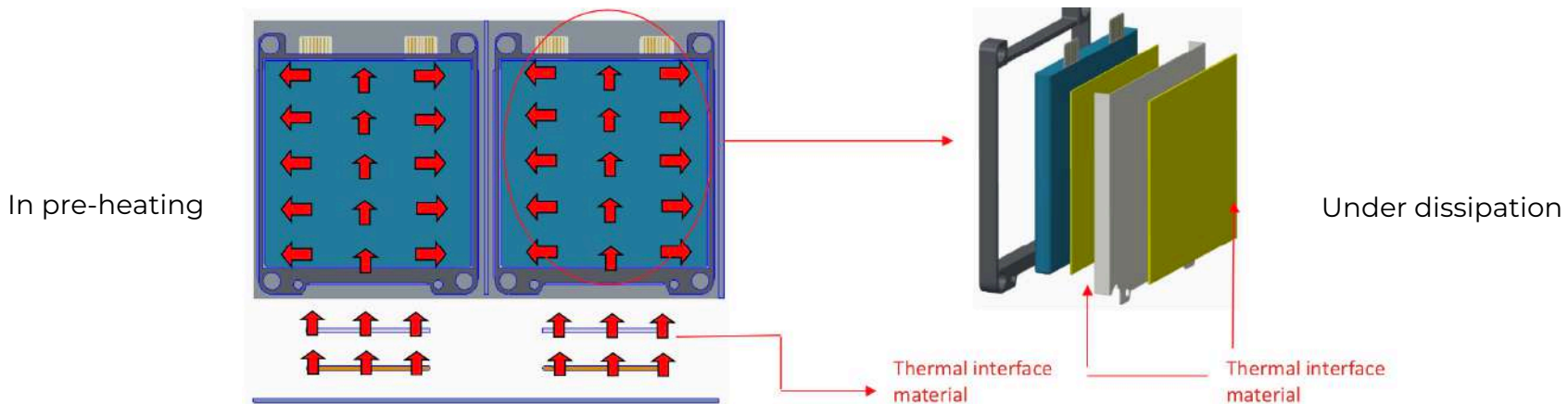

10 MINUTES' TEMPERATURE RISE SIMULATION OF SOFT PACKING POWER HEATING BATTERY

From the simulation results, it can be seen that in the scheme of heating battery module, the heat transfer efficiency can be effectively improved by filling the heating sheet and the heat transfer components in the battery module with the thermal interface material and the temperature of each component can be quickly balanced so that the battery module can enter the stable working state faster.

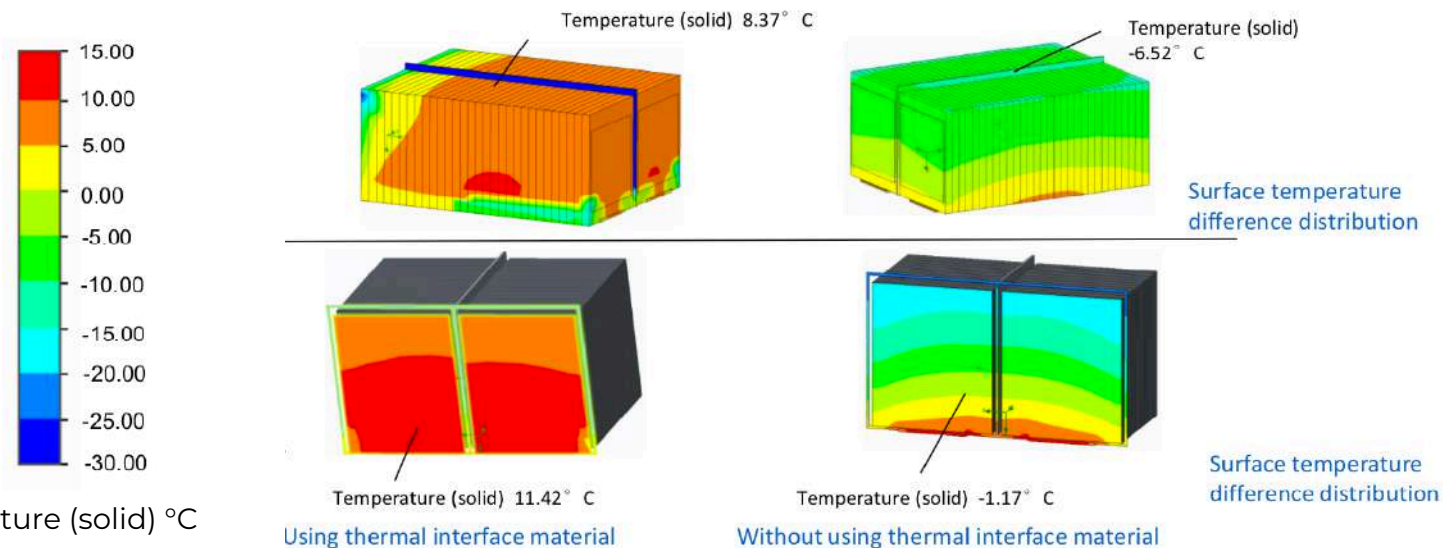

HARD SHELL BATTERY MODULES

HARD SHELL BATTERY MODULES

HARD SHELL BATTERY PACK STRUCTURE

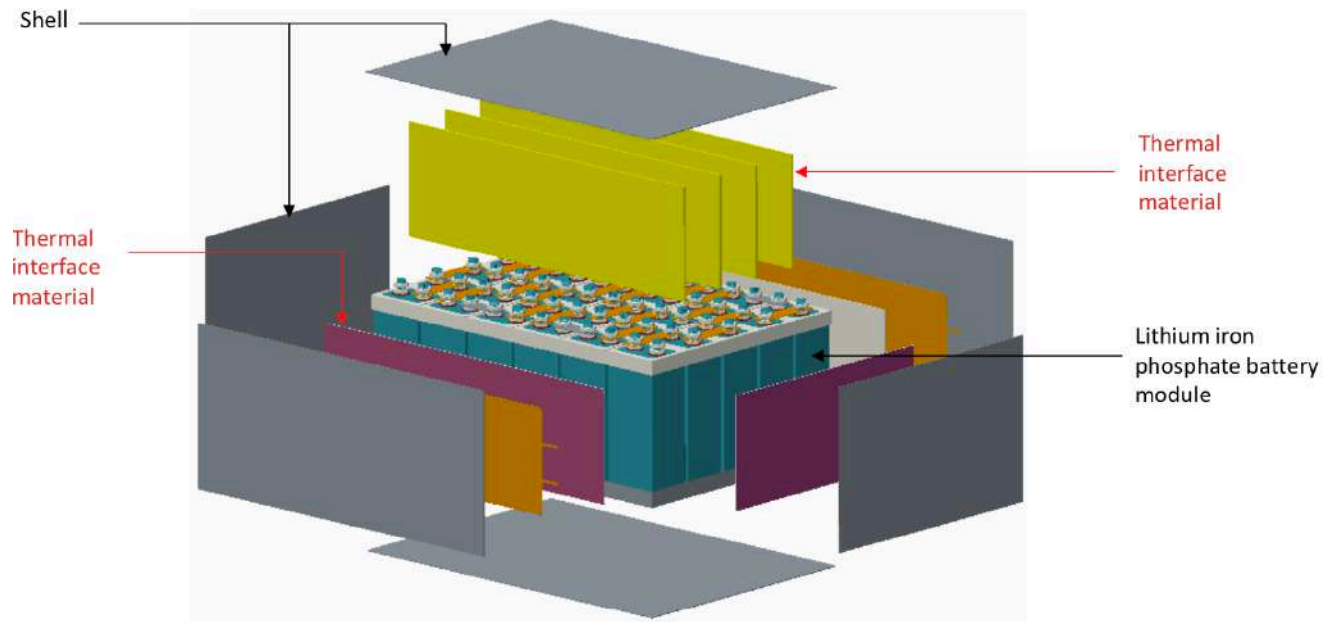

HARD SHELL BATTERY PACK

1. This scheme is also suitable for the natural heat dissipation scheme and the heating module scheme of the new energy vehicle battery module. When the temperature of the battery is too low, the side heating plate heats the preheating battery, and the heat is transferred to the thermal interface material filled in the battery module through the thermal interface material, and then to the battery cell, which can preheat the module uniformly and efficiently. The new energy vehicle can quickly enter the stable operation state. When the battery cell runs overheated, the heat of the battery is transmitted to the metal shell through the thermal interface material, which can quickly dissipate heat and ensure the safe and stable operation of the battery module.

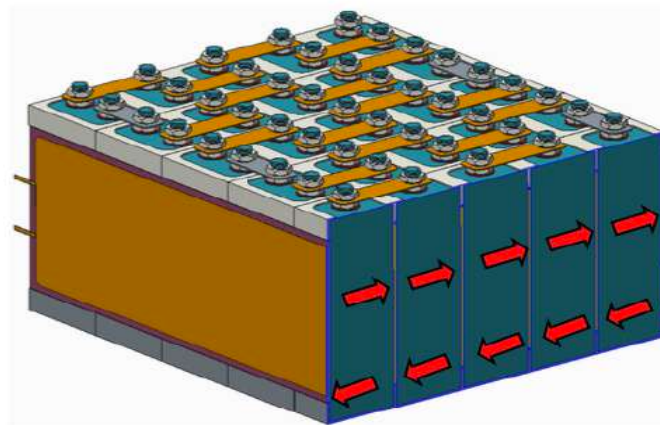
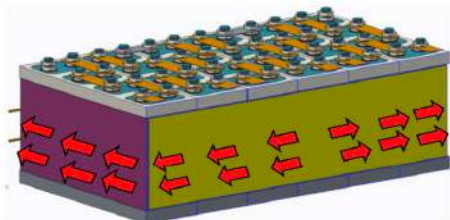

2. The thermal interface materials have good insulation and wear resistance, which can effectively protect the friction between the battery pack, heating sheet and shell and it can avoid wear, short circuit and other related safety problems.

NATURAL HEAT DISSIPATION SIMULATION OF POWER BATTERY PACK

Surface temperature difference distribution

When the thermal interface material is not used, the overall battery pack temperature is higher, and can not be concentrated in the central area of heat dissipation. There will be a risk of overheating.

After using the thermal interface material in the module, most of the heat is transferred to the shell through the material, and the temperature of the battery module can be controlled in a safe range.

Schematic diagram of temperature rise

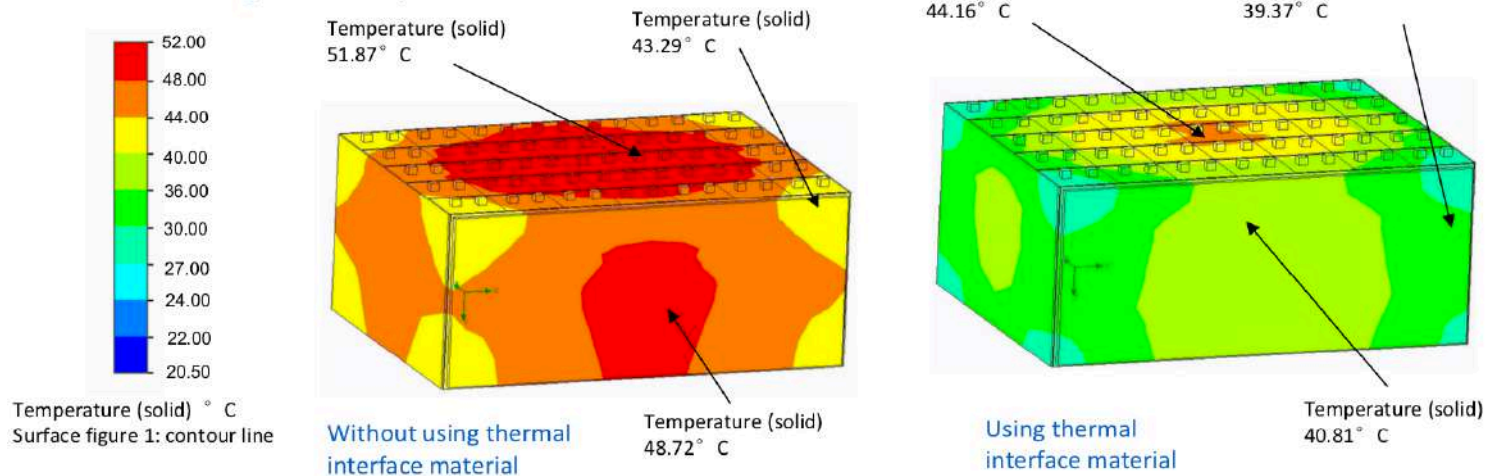

CHARGING PILE MODULES

HEAT DISSIPATION STRUCTURE OF CHARGING PILE MODULE

The charging pile module integrates a large number of high calorific electronic components, such as capacitors, inductances, MOS tubes, transformers, etc. It needs a built-in radiator to assist the electronic components to dissipate heat.

The thermal interface material like the silicone pad and thermal conductive adhesive are used between integrated electronic components board and radiator to play an important role in thermal conductivity, insulation protection, shock absorption, and fixing electronic components, so that the use of charging pile is more safe with longer service life.

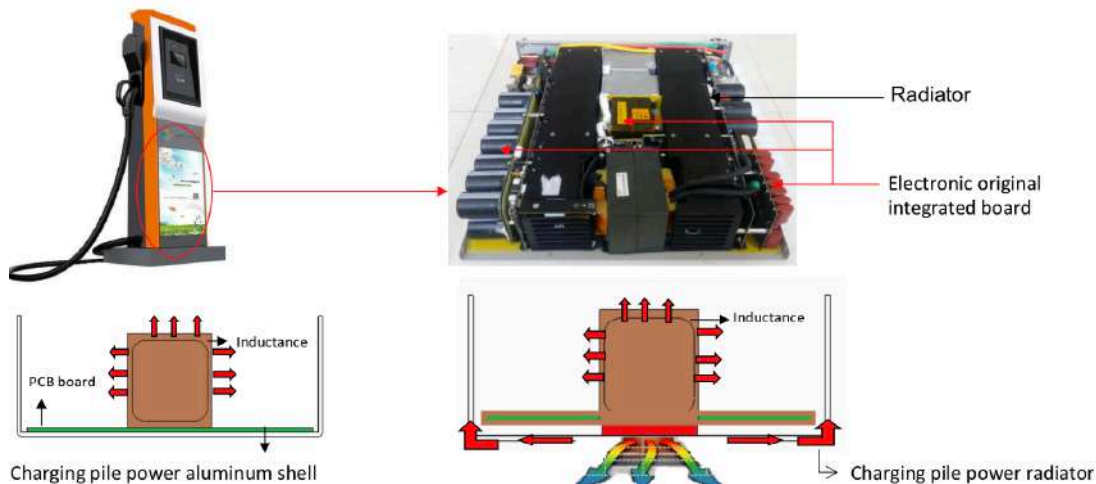

PRODUCT CATALOGUE

TIM/RF SHIELDING MATERIAL PORTFOLIOS / THERMAL INTERFACE MATERIALS

THERMAL PAD

THERMAL PUTTY / GEL

PHASE CHANGE MATERIAL

SILICONE FREE THERMAL PAD

FMC FOAM

GRAPHITE

OTHER PRODUCTS

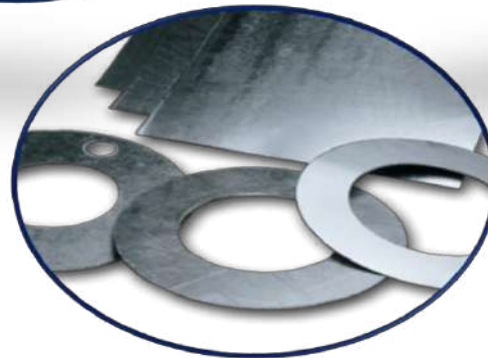
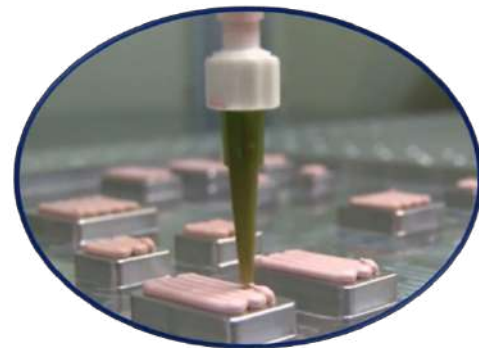
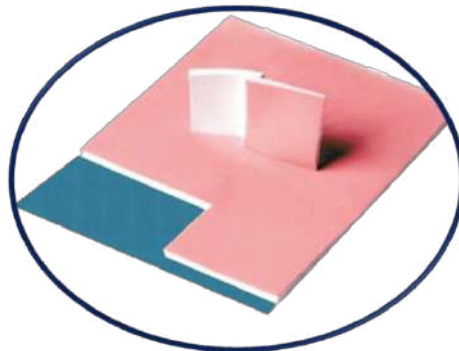

THERMAL PAD OVERVIEW

THERMAL CONDUCTIVITY	HARDNESS	COLOR
1.0 W/m.K	35 Shore 00	Pink
1.2 W/m.K	30 Shore 00	Light Grey
1.5 W/m.K	40 Shore 00	Light Blue
2.0 W/m.K	45 Shore 00	Orange
3.0 W/m.K	40 Shore 00	Blue
5.0 W/m.K	45 Shore 00	Violet
8.0 W/m.K	50 Shore 00	Grey
12.0 W/m.K	60 Shore 00	Ash Grey
1.1 W/m.K	5, 15 Shore C	Pink / White
35 W/m.K	20 Shore A	Black
50 W/m.K	50 Shore A	Black
60 W/m.K	60 Shore A	Black

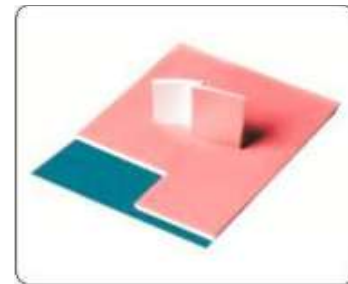

PREMIUM THERMAL PAD OVERVIEW

THERMAL CONDUCTIVITY	HARDNESS	COLOR
35 W/m.K	20 Shore A	Black
50 W/m.K	50 Shore A	Black
60 W/m.K	30 Shore A	Black

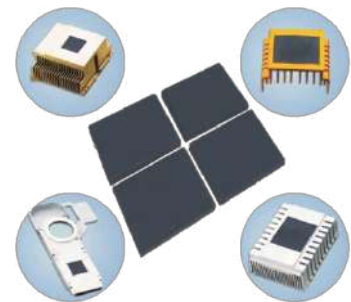

THERMAL PUTTY/GEL OVERVIEW

THERMAL CONDUCTIVITY	FLOW RATE	COLOR
3.5 W/m.K	20 g/min	Blue
6.0 W/m.K	10 g/min	Dark Red
9.0 W/m.K	10 g/min	Dark Grey



PHASE CHANGE MATERIAL (PCM) OVERVIEW

THERMAL CONDUCTIVITY	MELTING TEMPERATURE	COLOR
3.0 W/m.K	45 – 60 C	Light Grey
5.0 W/m.K	45 – 60 C	Black

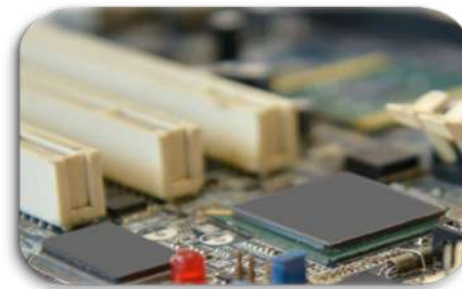

SILICONE-FREE THERMAL PAD OVERVIEW

THERMAL CONDUCTIVITY	HARDNESS	COLOR
3.0 W/m.K	45 Shore 00	Light Grey
5.0 W/m.K	60 Shore 00	Dark Grey

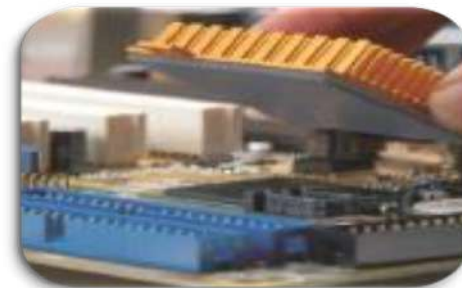

3D THERMAL PAD OVERVIEW

Design Criteria

- Thermal Conductivity: 1.0 – 6.0W/m.K
- Hardness: 30 – 50 Shore C
- Color: optional or per your requirement
- Min. Thickness: 0.5mm
- Structure: per the specific drawings and designs

Benefit and Feature

- Perfectly match to the irregular gap space
- Easy to assemble
- High performance and various options

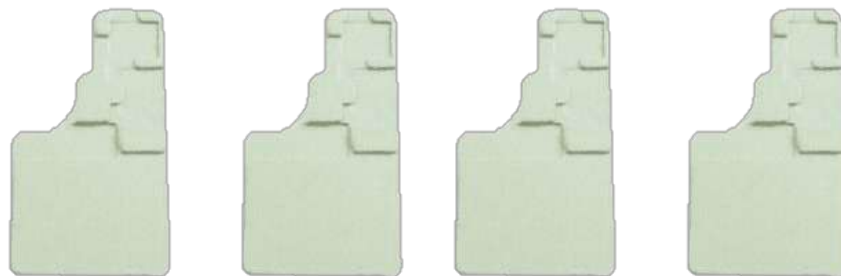

EMI SHIELDING MATERIALS



FIP SHIELDING GASKET OVERVIEW

CONDUCTIVE PARTICLES	SHIELDING EFFECTIVENESS (300 MHZ – 10 GHZ)	HARDNESS	COLOR	FIP
Ni/C	> 80 DB	65 Shore A	Grey	Automatic Dispensing
Ag/Cu	> 80 DB	50 Shore A	Silver White	Automatic Dispensing



EMC CONDUCTIVE FOAM OVERVIEW

SHIELDING EFFECTIVENESS (10 MHZ – 3 GHz)	SURFACE RESISTANCE (Ω /in ²)	Z AXIS RESISTANCE (Ω)
≥ 80 dB	≤ 0.048	≤ 0.07
≥ 60 dB	≤ 0.5	≤ 0.2



CF040 (XYZ Conductive Foam)



CF010 (Fabric-Over-Foam)

GRAPHITE OVERVIEW

PLAIN THERMAL CONDUCTIVITY	Z-AXIS THERMAL CONDUCTIVITY	ELECTRICAL RESISTANCE – Z-AXIS
420	5.5	310 $\mu\Omega\cdot\text{m}$
600	7.0	360 $\mu\Omega\cdot\text{m}$

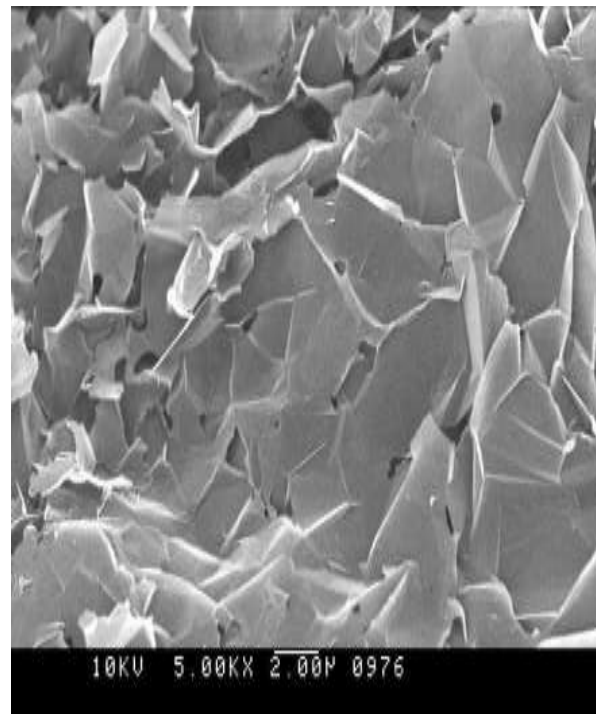
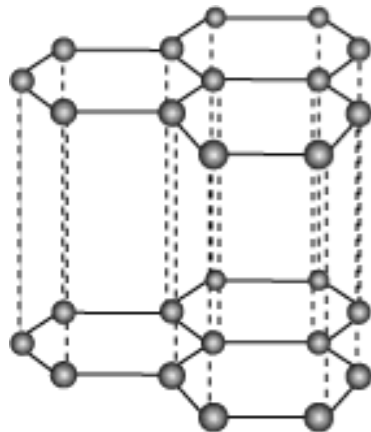

GRAPHITE OVERVIEW

Natural graphite

Function: Lubrication, sealing and flame retardancy

Synthetic graphite sheet

Function: High thermal conductivity, low thermal resistance

Maximum thermal conductivity reach 1600w/m.k
Minimum Thickness: 17um
Maximum size: 280mmX560mm
Excellent flexibility Bending performance over 1000 times



W/mK

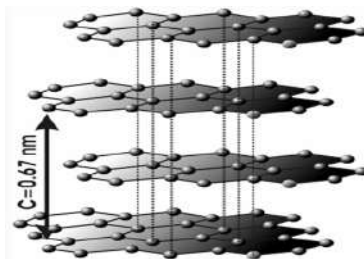
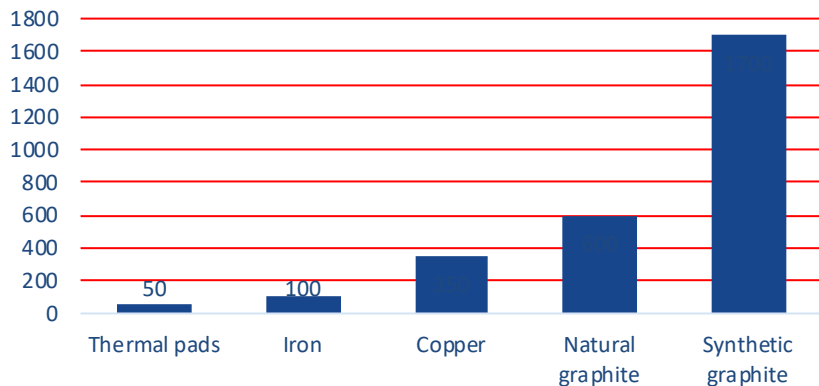

OTHER THERMAL PRODUCTS

THERMAL CONDUCTIVE INSULATOR / CAP

THERMAL CONDUCTIVE ABSORBER

THERMAL GREASE

COPPER FOIL

FMC FOAM

NANO-CARBON FILM

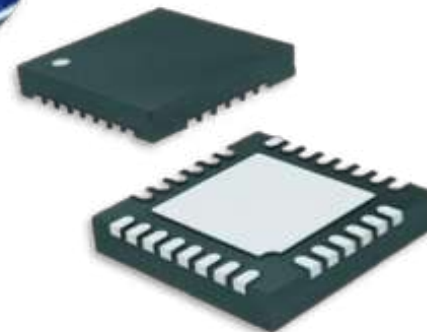

YOUR EXPERT PARTNER IN TECHNICAL PRINTING AND CUTTING



France

**Zone Industrielle de l'Argile II 123, 06370
Mouans Sartoux**

Tel. +33 (0)4 93 75 75 34

Fax: +33 (0)4 93 75 80 50

E-mail: salesfrance@gravicgroup.com



Tunisia

Z I route Khniss 5000 Monastir

Tel: (+216) 73 508 460

Fax: (+216) 73 508 563

E-mail: salestunisie@gravicgroup.com



Hungary

Kígyóhagyma út 2, H-4031 Debrecen

Tel. +36 52 531 994

Fax: +36 52 531 995

E-mail: saleshungary@gravicgroup.com



China

Shenzhen

E-mail: saleschina@gravicgroup.com